

**LECOL**

# **CONDUCTIVITY & CONCENTRATION SENSORS**

---

**LECOL OFFERS A COMPREHENSIVE RANGE OF CONDUCTIVITY SENSORS ENGINEERED FOR INDUSTRIAL ACCURACY AND RELIABILITY. FROM PRECISION TWO-ELECTRODE SENSORS TO ROBUST FOUR-ELECTRODE DESIGNS, OUR SOLUTIONS SUPPORT FLEXIBLE MOUNTING, BROAD ANALYSER COMPATIBILITY, AND DEMANDING PROCESS CONDITIONS—ENSURING STABLE PERFORMANCE ACROSS APPLICATIONS FROM ULTRAPURE WATER TO HIGH-CONDUCTIVITY CHEMICAL AND WASTEWATER STREAMS.**

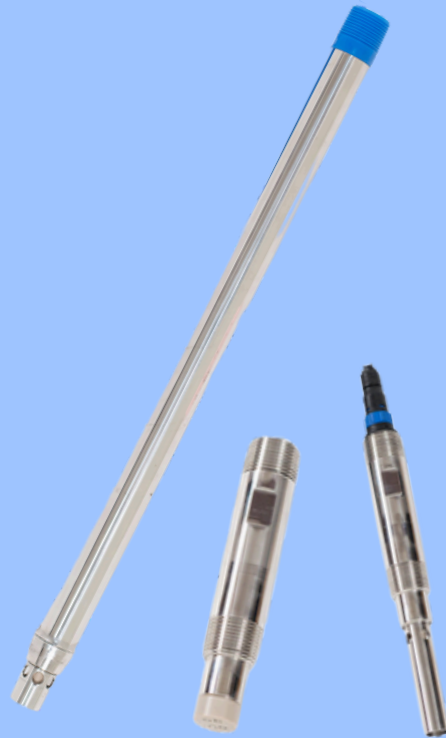

- **TWO ELECTRODE CONDUCTIVITY SENSORS**
  - **FOUR ELECTRODE CONDUCTIVITY SENSORS**
  - **FLEXIBLE MOUNTING SOLUTIONS FOR EVERY PROCESS**
  - **BROAD ANALYSER COMPATIBILITY**
-

LECOL conductivity sensors are engineered for precision and durability across a wide range of industrial applications. The product line includes robust two-electrode sensors for low-conductivity measurements and advanced four-electrode sensors for broader, high-accuracy measurement ranges up to 2,000 mS/cm. Designed for in-line, retractable, or hot-tap installations, these sensors are constructed with 316 SS electrodes, PEEK insulation, and Teflon-coated cables to withstand high pressure, temperature, and corrosive environments. Integrated PT100 or PT1000 temperature compensation ensures accurate readings across changing conditions. Compatible with all major conductivity transmitters, LECOL sensors offer a dependable upgrade for both new systems and sensor replacements.

- **Two Electrode Conductivity Sensors**

LECOL two-electrode conductivity sensors are ideal for pure and low-conductivity water like RO permeate and boiler feedwater. The LE91 model supports in-line installation with a detachable cable for easy maintenance. The LE92 model, suitable for both in-line and hot-tap installations, features a Teflon-coated cable for harsh environments. Both offer various cell constants ( $K = 0.01-1.0$ ) and built-in PT100/PT1000 for accurate temperature compensation and stable conductivity measurement.

- **Four Electrode Conductivity Sensors**

LECOL four-electrode conductivity sensors are designed for medium to high conductivity applications. The additional electrode pair reduces polarisation and fouling, enabling accurate measurement up to 2,000 mS/cm. The LE93 model supports in-line installation and features a detachable signal cable for easy maintenance. The LE94 model offers hot-tap (retractable) and immersion options for more demanding environments. Both models are compatible with major-brand transmitters, providing a robust and economical alternative to toroidal sensors in industrial processes.

- **Resilient Sealing Options**

To meet the needs of challenging applications, LECOL provides Viton™ and FFKM O-rings. These elastomers deliver superior performance against heat, solvents, and aggressive media, maintaining sensor integrity in critical processes.

- **Flexible Mounting Solutions for Every Process**

Offer multiple mounting options to suit various industrial setups, including in-line, immersion, and hot-tap configurations. Whether for pressurised pipelines or open tanks, LECOL sensors are engineered for flexibility, safe maintenance, and continuous operation—ensuring reliable measurement and easy integration into both new systems and retrofit applications.

- **Broad Analyzer Compatibility**

LECOL conductivity sensors are fully compatible with most standard analyzers and transmitters, ensuring seamless integration into existing systems. They offer an easy upgrade path—allowing direct sensor replacement without the need for major modifications. For smooth installation and configuration, wiring diagrams and signal output specifications are available upon request.

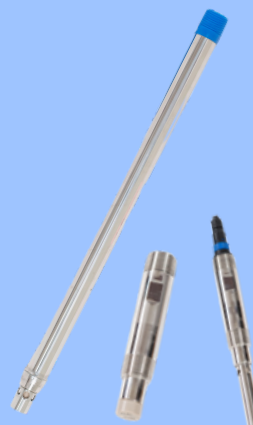

Building on expertise in industrial pH sensor technology, LECOL provides reliable measurement solutions, including a full range of two- and four-electrode industrial conductivity sensors to support your applications.

In industrial and environmental applications alike, the ability to monitor and control the quality of liquids is essential. One of the most direct and informative ways to achieve this is through the measurement of electrical conductivity—a parameter that reflects how well a liquid can carry an electric current.

Conductivity arises from the presence of dissolved ions, such as salts, acids, or alkalis, which act as charge carriers. The higher the concentration of these ions, the greater the conductivity of the solution. This simple principle underpins a wide range of applications, from ultrapure water monitoring in semiconductor manufacturing to process control in chemical plants.

To quantify conductivity, the unit commonly used is microsiemens per centimetre ( $\mu\text{S}/\text{cm}$ ) or, for more conductive solutions, millisiemens per centimetre ( $\text{mS}/\text{cm}$ ). However, accurate measurement requires more than just detecting current flow—it also depends on the geometry of the sensor.

The K cell constant—commonly referred to as the K value—is the most important factor when selecting a conductivity sensor. It defines the physical characteristics of the sensor, specifically the distance between the electrodes and their surface area, and directly determines the sensor's measurement range.

Whether you're measuring ultrapure water in a pharmaceutical system or high-concentration process fluids in a chemical plant, the K value ensures that your sensor is appropriately matched to the task. Using a sensor with the wrong K value can result in inaccurate readings, poor sensitivity, or unstable performance.

## TWO-ELECTRODE CONDUCTIVITY SENSORS

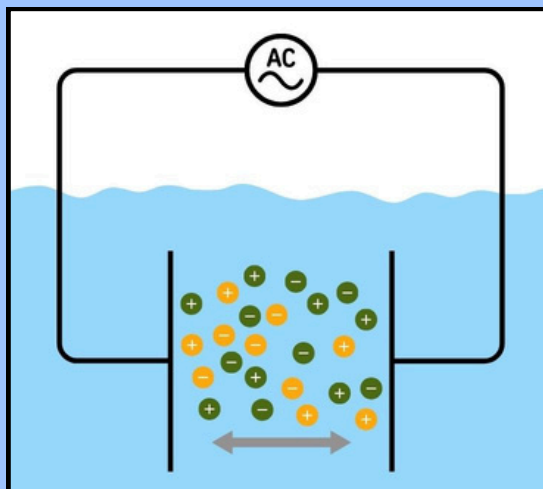

Two-electrode (contacting) conductivity sensors consist of a pair of electrodes—typically metal—that are directly immersed in the liquid. An alternating current is passed through the solution, and the voltage drop is measured to determine conductivity.

Features:

- Ideal for low- to mid-range conductivity measurements
- Cost-effective and simple design
- Susceptible to polarisation in high-conductivity or fouling environments

Typical Applications:

- Portable water
- Cooling towers
- Rinse water monitoring
- General industrial water treatment

## FOUR-ELECTRODE CONDUCTIVITY SENSORS

Four-electrode sensors use two inner electrodes to measure voltage and two outer electrodes to pass current. This design minimises polarisation and improves accuracy across a wide range of conductivities.

Features:

- Wide dynamic range
- High accuracy in fouling or high-conductivity environments
- Less affected by coating or scale on electrodes

Typical Applications:

- Chemical manufacturing
- Wastewater treatment
- CIP (Clean-in-Place) systems
- High-concentration process fluids

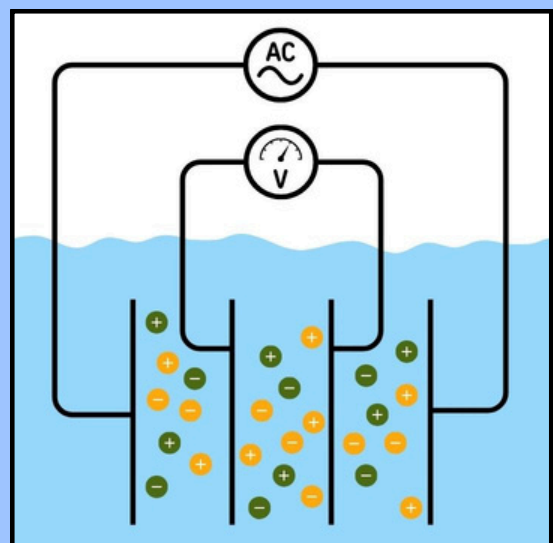

# OPERATING RANGES FOR TWO- AND FOUR-ELECTRODE CONDUCTIVITY SENSORS

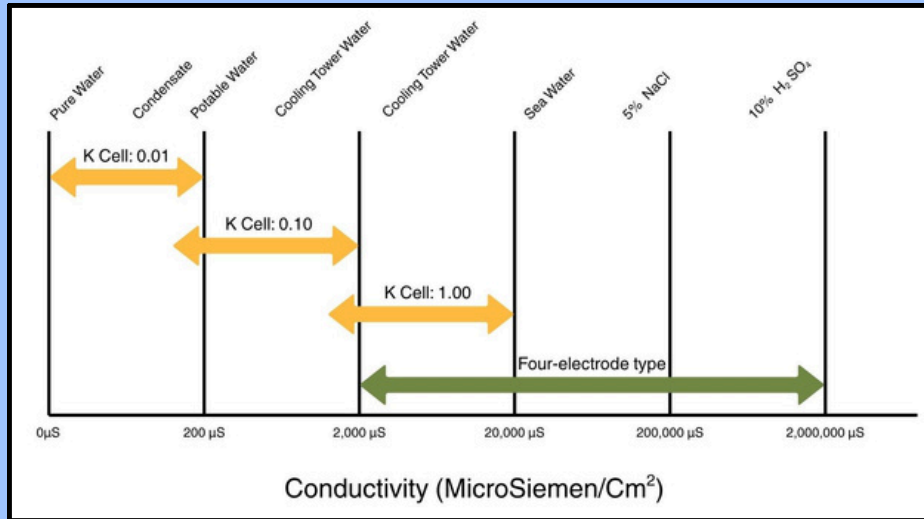

## SENSOR WIRING

**TINNED LEADS-  
APPLY FOR TWO-ELECTRODE CONDUCTIVITY SENSOR (LE92)**

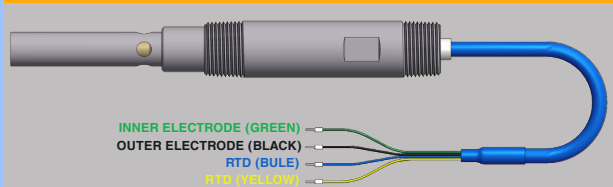

**TINNED LEADS-  
APPLY FOR TWO-ELECTRODE CONDUCTIVITY SENSOR (LE92)**

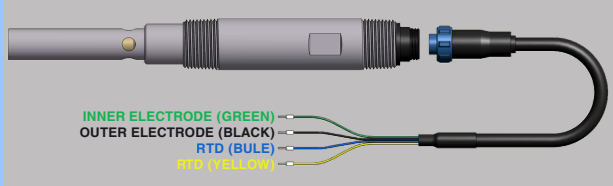

**TINNED LEADS-  
APPLY FOR FOUR-ELECTRODE CONDUCTIVITY SENSOR (LE94)**

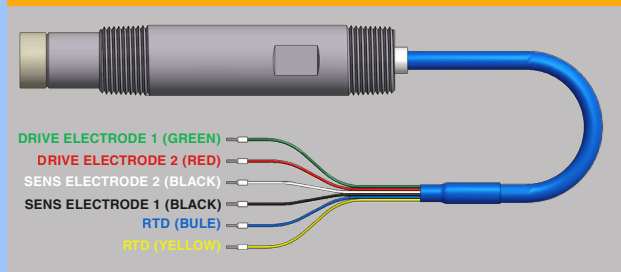

### TEMPERATURE COMPENSATION

- PT100 RTD
- PT1000 RTD

### COMPRESSION FITTING MATERIAL OPTION

- VITON
- FFKM

### COMPRESSION FITTING MATERIAL OPTION

- 316SS (P/N:LECFSS)
- HASTELLOY C276 (P/N:LECFHS)
- TITANIUM (P/N:LECFTS)

### 316SS ISOLATION VALVE SIZE OPTION

- 1-1/4 IN. NPT, INCLUDES 1" TO 1-1/4" REDUCING BUSHING & 1-1/4"NIPPLE (P/N: LEIV-B01)
- 1-1/4 IN. NPT, INCLUDES 1-1/2" TO 1" REDUCING BUSHING & 1-1/2"NIPPLE (P/N: LEIV-A01)

## SENSOR INTSALLATION RECOMMENDATION

### IN-LINE TYPE



IN-LINE TYPE

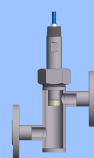

316 SS FLOW CHAMBER  
• 1/2 IN. FNPT  
WITH FLANGE  
• 1/2 IN. 150#RF  
• 3/4 IN. 150#RF  
• 1 IN. 150#RF

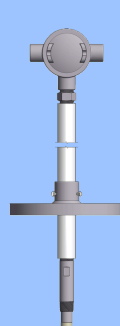

IMMERSION PIPE

### HOT-TAP TYPE

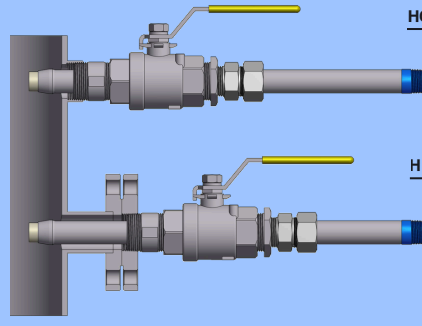

HOT-TAP

HOT-TAP WITH FLANGE

# LE91 THREADED TWO-ELECTRODE CONDUCTIVITY SENSOR

The LECOL LE91 two-electrode conductivity sensor features a detachable cable for easy installation and maintenance. Made of corrosion-resistant 316 stainless steel, it suits harsh environments. With various cell constants, it measures 0–20000  $\mu\text{S}/\text{cm}$  and is ideal for low-conductivity applications. PEEK insulation handles up to 120 °C.

Specifications	
Measuring range	: 0.01 : 0~2 to 0~200 $\mu\text{S}/\text{cm}$
	0.10 : 0~20 to 0~2000 $\mu\text{S}/\text{cm}$
	1.00 : 0~200 to 0~20000 $\mu\text{S}/\text{cm}$
Material	: Body : 316SS
	Electrodes : 316SS
	O-ring : Viton FFKM(Optional)
	Insulator : PEEK
Temp. compensator	: PT100
	PT1000
Operating temperature	: 120 °C
Operating rating	: 10 bar, in-line type
Process connection	: 3/4 in. NPT
Detachable connector rating	: IP68



## Applications for LE91

- Pure water (low conductivity)
- Boiler-feed water quality
- Cooling tower water
- Water for injection (biopharma)
- Potable water
- Distilled water
- Water for injection (biopharma)

## Dimensions

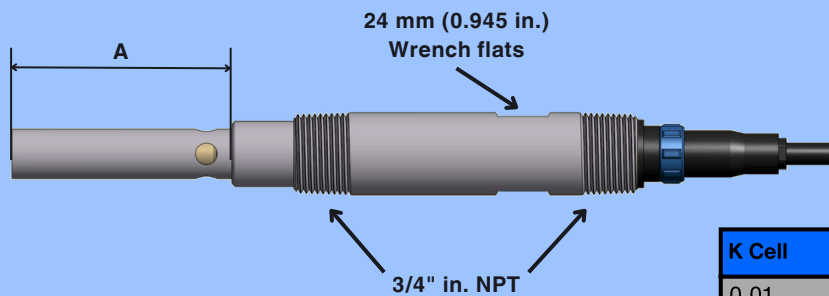

K Cell	Electrode length A
0.01	71 mm (2.795 in.)
0.10	24.5 mm (0.965 in.)
1.00	74.5 mm (2.993 in.)

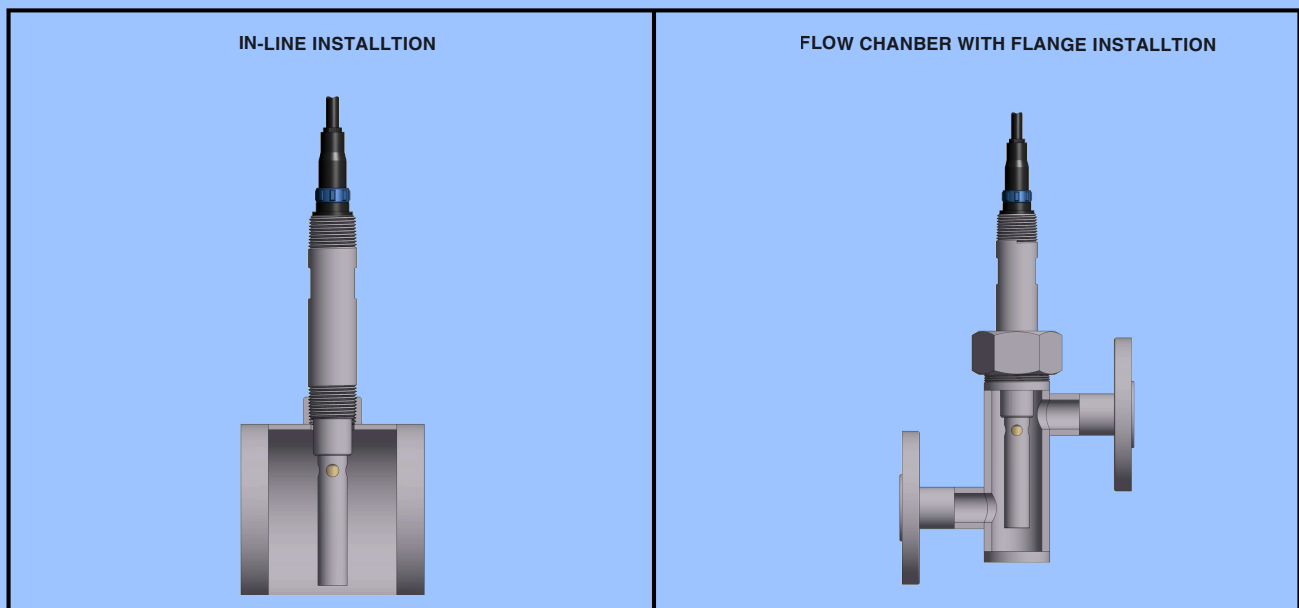

## Threaded Two-electrode Conductivity Sensor

**Model: LE91**

X-

X-

X-

X-

X-

X

### A Body style

0 In-line / Flow through

### B Cell constant

0 0.01 : 0~2 TO 0~200  $\mu\text{S/cm}$

1 0.10 : 0~20 TO 0~2000  $\mu\text{S/cm}$

2 1.00 : 0~200 TO 0~20000  $\mu\text{S/cm}$

### C Temperature compensator

0 None

1 PT100, tinned leads

2 PT1000, tinned leads

### D O-ring

0 Viton

1 FFKM

### E Cable length

1 3M

2 6M

3 10M

4 15M

5 30M

### F Accessory

0 None

Flow Chamber 316 SS

1 1/2 in. FNPT P/N: LEFCB6-ST12

2 1/2 in. 150#RF P/N: LEFCB6-SF12

3 3/4 in. 150#RF P/N: LEFCB6-SF34

4 1 in. 150#RF P/N: LEFCB6-SF11

8 Junction Box P/N: LEJB

# LE92 TWO-ELECTRODE CONDUCTIVITY SENSOR

The LECOL LE92 is a two-electrode conductivity sensor for in-line or retractable installation, compatible with 3/4" NPT or 1-1/4" hot-tap valves. It features a Teflon-coated signal cable for high-temperature, corrosive environments. With 316 SS construction, PEEK insulation, and PT100/PT1000 support, it's ideal for low-conductivity water applications. Optional accessories include C276 or titanium components and FFKM O-rings, offering enhanced resistance for aggressive chemical processes.

Specifications	
Measuring range	: 0.01 : 0~2 to 0~200 $\mu\text{S/cm}$
	: 0.10 : 0~20 to 0~2000 $\mu\text{S/cm}$
	: 1.00 : 0~200 to 0~20000 $\mu\text{S/cm}$
Material	: Body : 316SS (In-line) 316L SS (Hot tap)
	: Electrodes : 316SS
	: O-ring : Viton FFKM(Optional)
	: Insulator : PEEK
	: Temp. compensator : PT100 PT1000
Operating temperature	: 200 °C max, In-line type
	: 120 °C max, Hot tap type
Operating rating	: 10 bar max, in-line type
	: 5 bar max, Hot tap type
Process connection	: 3/4 in. NPT, In-line type
Retractable body length	: 16" (standard), 24", 32" and 36" (optional)
Cable material	: teflon coating

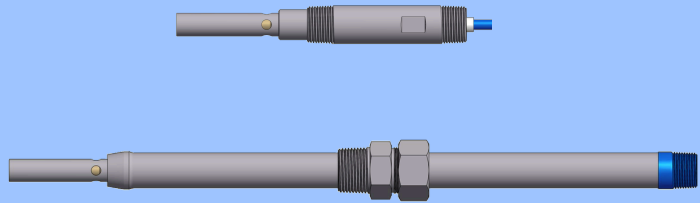

### Applications for LE92

- Pure water (low conductivity)
- Caustic & salt conductivity
- Caustic & salt concentration
- Clean-in-place control
- Liquid interface

### Dimensions

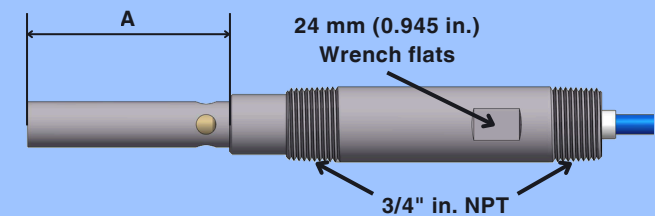

K Cell	Electrode length A
0.01	71 mm (2.795 in.)
0.10	24.5 mm (0.965 in.)
1.00	74.5 mm (2.993 in.)

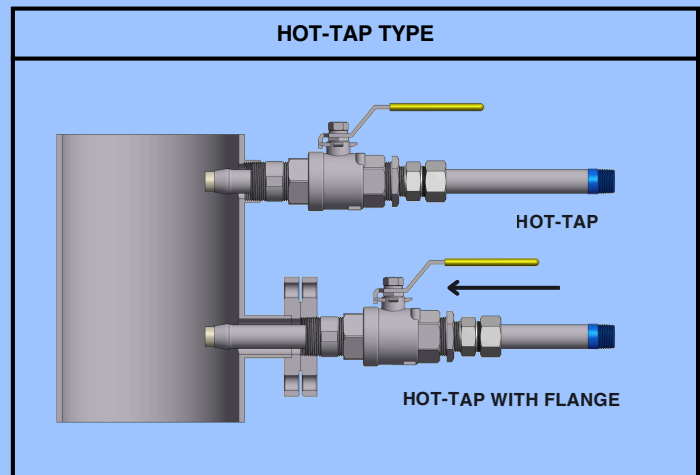
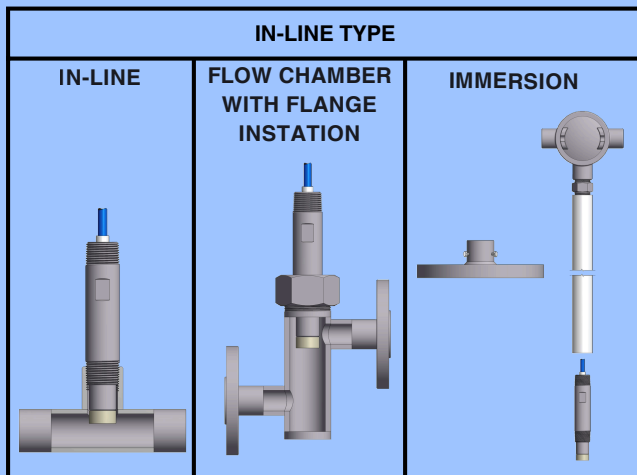
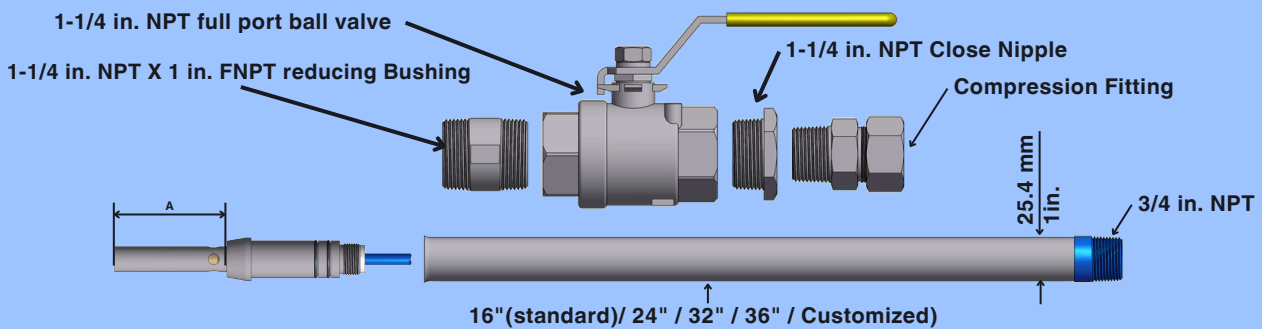

Two-electrode Conductivity Sensor									
Model: LE92	X-	X-	X-	X-	X-	X-	X	X-	X
<b>A Body style</b>									
0 In-line / Immersion type									
1 Hot-Tap insertion									
<b>B Cell constant</b>									
0 0.01 : 0~2 TO 0~200 $\mu$ S/cm									
1 0.10 : 0~20 TO 0~2000 $\mu$ S/cm									
2 1.00 : 0~200 TO 0~20000 $\mu$ S/cm									
<b>C Temperature compensator</b>									
0 None									
1 PT100, tinned leads									
2 PT1000, tinned leads									
<b>D O-ring</b>									
0 Viton									
1 FFKM									
<b>E Outer Sleeve sheath</b>									
0 None, in-line/immersion									
1 16 in. Hot tap, (P/N:LEIV-01)									
2 24 in. Hot tap, (P/N:LEIV-02)									
3 32 in. Hot tap, (P/N:LEIV-03)									
4 36 in. Hot tap, (P/N:LEIV-04)									
5 16 in. Hot tap, for higher temperature, (P/N:LEIV-11)									
6 24 in. Hot tap, for higher temperature, (P/N:LEIV-11)									
<b>F Compressing fitting/ O-ring, Hardware</b>									
0 None									
1 316SS Compression fitting/ Viton O-ring P/N:LECFSS-V									
2 316SS Compression fitting/ FFKM O-ring P/N:LECFSS-F									
3 Titanium Compression fitting/ Viton O-ring P/N:LECFSS-V									
4 Titanium Compression fitting/ FFKM O-ring P/N:LECFSS-F									
5 C276 Compression fitting/ Viton O-ring P/N:LECFHS-V									
6 C276 Compression fitting/ FFKM O-ring P/N:LECFHS-F									
<b>G Isolation Valve</b>									
0 None									
1 316 SS, 1-1/4 in. NPT P/N: LEIV-B01 (includes 1" to 1-1/4" reducing bushing & 1-1/4" nipple)									
2 316 SS, 1-1/2 in. NPT P/N: LEIV-A01 (includes 1-1/2" to 1" reducing bushing & 1-1/2" nipple)									
<b>H Cable length</b>									
0 No cable, Junction Box									
1 3M									
2 6M									
3 10M									
4 15M									
5 30M									
<b>I Accessory</b>									
0 None									
1 316SS Flow chamber, 1/2 in. NPT connection P/N:LEFC24-ST12									
2 316SS Extension sleeve length 70 mm P/N:LEX70									
3 316SS Extension sleeve length 125 mm P/N:LEX125									

## LE93 THREADED FOUR-ELECTRODE CONDUCTIVITY/CONCENTRATION SENSOR

The LECOL LE93 four-electrode conductivity sensor provides wide-range, high-accuracy measurement up to 2,000,000  $\mu\text{S}/\text{cm}$  by minimising ion polarisation. Designed for in-line or flow cell installation with a 3/4" NPT connection, it features a 316 SS body, detachable cable, and PT100/PT1000 temperature compensation for harsh, dynamic industrial environments.

Specifications	
Measuring range	: 0 ~ 2,000,000 $\mu\text{S}/\text{cm}$
Material	: Body : 316SS
	: Electrodes : 316SS
	: O-ring : Viton
	: FFKM(Optional)
Temp. compensator	: PT100
	: PT1000
Operating temperature	: 120 °C
Operating rating	: 10 bar, in-line type
Process connection	: 3/4 in. NPT
Detachable connector rating	: IP68



### Applications for LE93

- Caustic & salt conductivity
- Caustic & salt concentration
- Oil and water interface
- Clean-in-place control
- Liquid interface

### Dimensions

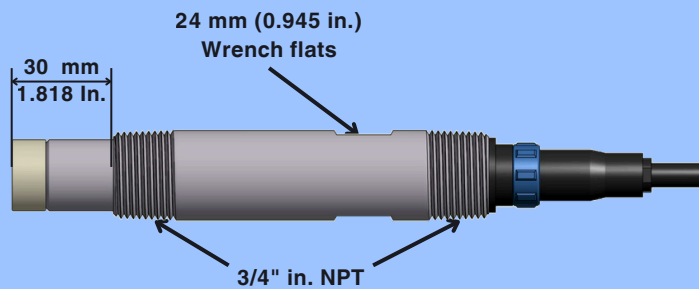

IN-LINE INSTANTION



FLOW CHAMBER WITH FLANGE INSTANTION

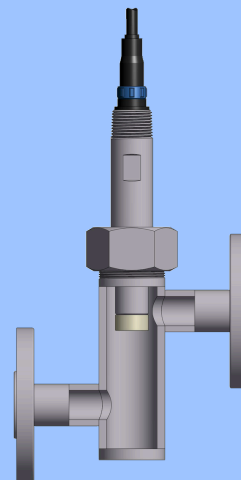

**Threaded four-electrode Conductivity/Concentration Sensor**

**Model: LE93**

X-

X-

X-

X-

X

**A Body style**

0 In-line / Flow through

**B Temperature compensator**

0 None

1 PT100, tinned leads

2 PT1000, tinned leads

**D O-ring**

0 Viton

1 FFKM

**E Cable length**

1 3M

2 6M

3 10M

4 15M

5 30M

**F Accessory**

0 None

Flow Chamber 316 SS

1 1/2 in. FNPT

P/N: LEFCB6-ST12

2 1/2 in. 150#RF

P/N: LEFCB6-SF12

3 3/4 in. 150#RF

P/N: LEFCB6-SF34

4 1 in. 150#RF

P/N: LEFCB6-SF11

# FOUR-ELECTRODE CONDUCTIVITY/CONCENTRATION SENSOR

The LECOL LE94 is a four-electrode conductivity sensor designed for in-line, retractable, or hot-tap installation. It offers high accuracy up to 2,000 mS/cm, with 316 SS construction and PT100/PT1000 options. A Teflon-coated cable withstands high temperatures and harsh environments, ensuring durability and easy integration in industrial processes. Optional accessories include C276 or titanium components and FFKM O-rings, offering enhanced resistance for aggressive chemical processes.

Specifications		
Measuring range	: 0 ~ 2,000,000	μS/cm
Material	: Body	: 316SS (In-line) 316L SS (Hot tap)
	: Electrodes	: 316SS
O-ring	: Viton	
	: Insulator	: PEEK FFKM(Optional)
Temp. compensator	: PT100	
	: PT1000	
Operating temperature	: 200 °C max, In-line type	
	: 120 °C max, Hot tap type	
Operating rating	: 10 bar max, in-line type	
	: 6 bar max, Hot tap type	
Process connection	: 3/4 in. NPT, In-line type	
Retractable body length	: 16" (standard), 24", 32" and 36" (optional)	

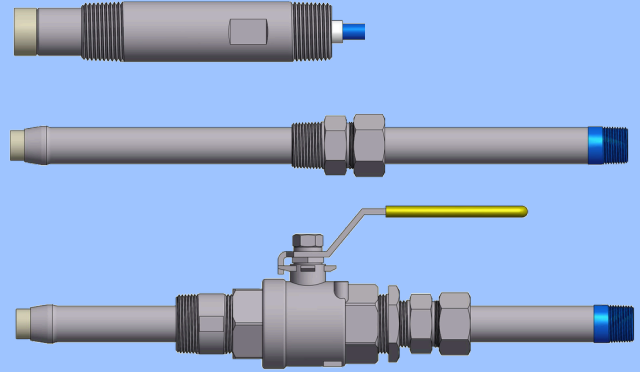

### Applications for LE94

- Caustic & salt conductivity
- Caustic & salt concentration
- Oil and water interface
- Clean-in-place control
- Liquid interface

### Dimensions

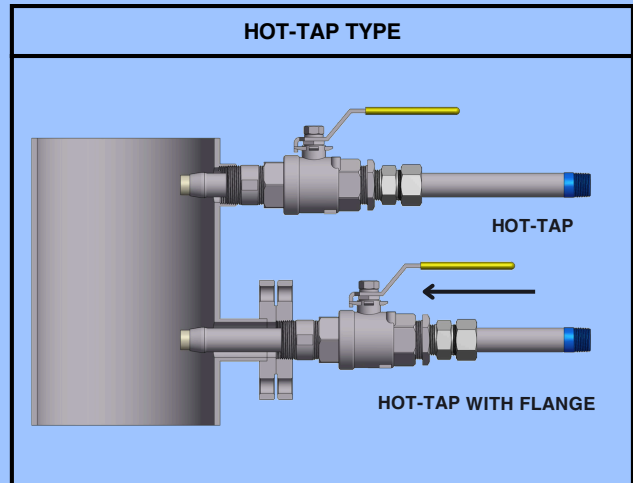
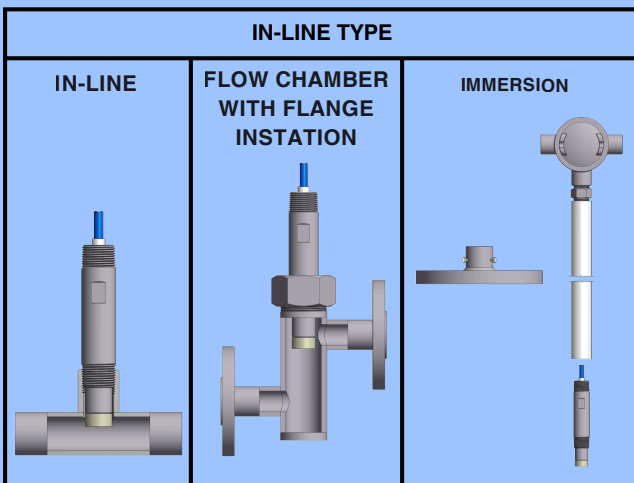
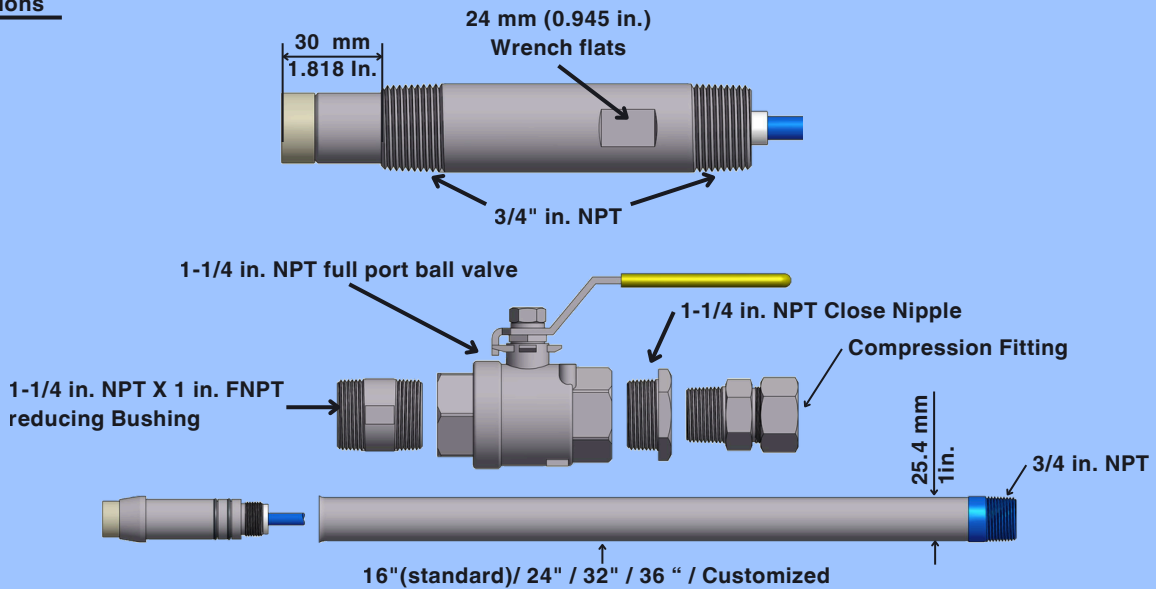

Four-electrode Conductivity/Concentration Sensor								
Model: LE94	X-	X-	X-	X-	X-	X-	X	X
<b>A Body style</b>								
0 In-line / Immersion type								
1 Hot-Tap insertion								
<b>B Temperature compensator</b>								
0 None								
1 PT100, tinned leads								
2 PT1000, tinned leads								
<b>C O-ring</b>								
0 Viton								
1 FFKM								
<b>D Outer Sleeve sheath</b>								
0 None, in-line/immersion								
1 16 in. Hot tap, (P/N:LEIV-01)								
2 24 in. Hot tap, (P/N:LEIV-02)								
3 32 in. Hot tap, (P/N:LEIV-03)								
4 36 in. Hot tap, (P/N:LEIV-04)								
5 16 in. Hot tap, for higher temperature, (P/N:LEIV-11)								
6 24 in. Hot tap, for higher temperature, (P/N:LEIV-11)								
<b>E Compressing fitting/ O-ring, Hardware</b>								
0 None								
1 316SS Compression fitting/ Viton O-ring P/N:LECFSS-V								
2 316SS Compression fitting/ FFKM O-ring P/N:LECFSS-F								
3 Titanium Compression fitting/ Viton O-ring P/N:LECFTS-V								
4 Titanium Compression fitting/ FFKM O-ring P/N:LECFTS-F								
5 C276 Compression fitting/ Viton O-ring P/N:LECFHS-V								
6 C276 Compression fitting/ FFKM O-ring P/N:LECFHS-F								
<b>G Isolation Valve</b>								
0 None								
1 316 SS, 1-1/4 in. NPT P/N: LEIV-B01 (includes 1" to 1-1/4" reducing bushing & 1-1/4"nipple)								
2 316 SS, 1-1/2 in. NPT P/N: LEIV-A01 (includes 1-1/2" to 1" reducing bushing & 1-1/2"nipple)								
<b>H Cable length</b>								
0 No cable, Junction Box								
1 3M								
2 6M								
3 10M								
4 15M								
5 30M								
<b>I Accessory</b>								
0 None								
1 316SS Flow chamber, 1/2 in. NPT connection								
2 316SS Extension sleeve length 70 mm								
3 316SS Extension sleeve length 125 mm								

---

**Luh Cherng Enterprises co., Ltd.**

**No. 42, Mei-shan Rd., Niasong Dist., Kaohsiung City 83346, Taiwan**

**TEL : +886-7-733-6377**

**FAX : +886-7-733-6353**

**E-mail : [sales@lecoltw.com](mailto:sales@lecoltw.com)**

**Website : [www.lecoltw.com](http://www.lecoltw.com)**

